

# AR663.B

# UNIVERSAL CONTROLLER WITH TWO ROW DISPLAY



## Two channel process controller with autotuning PID parameters functions



**2 Inputs**  
RTD, TC, mA  
V, mV, Ω, BIN



**Output**  
3 x P/SSR  
1 x mA/V



**Control**  
ON/OFF, PID  
Program, Servo



**Alarms**  
**STB function**  
LATCH



**Protection rating**  
Front



**RS485**  
MODBUS-RTU



**USB**  
port COM  
MODBUS-RTU



**Ethernet**  
MODBUS-TCP  
MQTT



**Software**  
ARSOFT-CFG



Bargraph  
8-segment

- control and monitoring of temperature and other physical values (humidity, pressure, flow rate, level, speed, ect.) processed to a standard electrical signal
- configurable architecture enabling use in many fields and applications (industrial, heating, food, energy, etc.)
- **2 universal measuring input** (resistance thermometers, thermocouple, analogue 0/4÷20mA, 0÷10V, 0÷60mV, 0÷2,5kΩ) **with mathematical functions** (difference, sum, average, greater or lesser of the measurements) available independently for displaying and controlling control/alarm outputs
- **2 function buttons** (F i SET) and digital input (**BIN**) for quick selection operating mode of controller, separately programmable: start/stop of control, manual/ automatic mode
- for outputs, step change of the set point value SP (day / night, with separate control parameters), keyboard lock, resetting errors and alarms STB (LATCH), unconditional
- preview of measured values from inputs 1 and 2
- **3 control/alarm outputs** ON/OFF type (two-state P/SSR) with independent functionalities and control algorithms (setpoints defined by the parameter or taken from the measurement input 1/2):
  - ON-OFF with hysteresis (characteristics for heating and cooling, band alarms in range, out of range and with deviation for 3-position control)
  - **PID** (choice of **3 separate sets of parameters**, gain scheduling for SP setpoint taken from measurement input 1 or 2), advanced functions of automatic selection of PID smart logic parameters
  - programmed control characteristic (**process controller with timer**, up to **6 sections**, including 3 ramping sections - inclination for heating/cooling or for cooling/defrosting, 3 setpoints SP with ON-OFF or PID control, selection of the auxiliary output and its status, displaying remaining time for the entire section or after exceeding SP, etc.)
  - thermostat/ safety controller **STB** (alarm state open or closed, can be used as **LATCH alarm memory** e.g. when exceeds a threshold or a band)
  - ability to control a three-way mixing valve with an actuator (**step control, Servo**) with two contact inputs (open - close)
  - **manual mode** (open control loop) with initial value of control signal (MV) taken from current automatic mode or programmed by user
  - direct or inverse copy of the output 1 state (applies to outputs 2 and 3, can be used e.g. to implement **DPDT** changeover relay or to take over the function of the damaged P1)
  - **limiting** maximum level of output signal (**power**), also includes associated mA/V analog output
- analog output 0/4÷20mA lub 0/2÷10V for control or retransmission of measurements and set values:
  - getting control parameters from any associated two state output (1, 2, 3), both in automatic and manual mode
  - shockless (soft) switching of the output signal, e.g. after changing manual/automatic mode or control start/stop
  - correction (calibration) of range of changes of output signal (offset for end values to obtain non-standard ranges e.g. 2÷16mA or 1÷9V)
- wide range of supply voltages (**18÷265 Vac / 22÷350 Vdc**) and built-in power supply for supplying on-site transducers **24Vdc/50mA**
- **readable LED** display with adjustable brightness, typical **units of measurement** and signaling work status (messages, errors, etc.):
  - white color - measured value PV (upper row), units and symbols of status of outputs and serial transmissions (1, 2, 3, °C, %, %RH, mA, A, mV, V, m, . or none)
  - red, bottom row - selectable setpoints SP or 8-segment **bargraph** for MV (control signal), PV (measurement), output signal mA/V or none)
- optional **RS485** serial interface, protocol **MODBUS-RTU** for reading measurements and parameter configuration
- optional **Ethernet** interface, protocol **MODBUS-TCP** i **MQTT** (for internet of things **IoT/M2M**, a cloud and mobile applications), possibility of data exchange via the **Internet**
- USB interface (micro USB port, standard equipment, for parameter programming, viewing measurements and updating firmware)
- automatic or fixed line resistance compensation for resistive sensors and thermocouple cold junction temperature compensation
- programmable type of input, indication range (for analog inputs), control options, alarms, display, communication, access, and other configuration parameters
- access to configuration parameters protected with a user password or without protection
- methods for configuring parameters:
  - via membrane keyboard IP65 located on the front panel
  - via USB, RS485 or Ethernet and freeware ARsoft-CFG (for Windows 7/10) or user application (using protocols MODBUS-RTU i TCP)
- free software ARSOFT-CFG (download from [www.apar.pl](http://www.apar.pl)) enabling the preview of measured value and quick configuration single or ready parameter sets previously saved on a computer for re-use, e.g. in other controllers of the same type (duplicate configuration)
- housing for mounting on a 35 mm DIN rail, protection class IP40 (IP20 from the side of connectors)
- modern technical solutions, intuitive and clear operation, **high accuracy** and long-term stability as well as resistance to interference
- optional to choose from (in the way of ordering): control outputs for SSR, analog output 0/2÷10V (instead 0/4÷20mA) and RS485 and Ethernet interface (RJ45 conenctor)
- **Contents of set:**
  - controller with handles mounting
- **Available accessories:**
  - USB cable (A - micro B) for connection with a computer, length 1.5 m
- user manual

## TECHNICAL DATA

<b>Number of measuring inputs</b>	2 universals (resistance thermometer RTD, thermocouple, analog mA/V/I)		
<b>Universal input</b> (programmable, 17 types, conversion A/C 18 bits), measuring ranges			
- Pt100 (RTD, 3- or 2-wire)	-200 ÷ 850 °C	- thermocouple R (TC, PtRh13-Pt)	-40 ÷ 1600 °C
- Pt500 (RTD, 3- or 2-wire)	-200 ÷ 620 °C	- thermocouple T (TC, Cu-CuNi)	-25 ÷ 350 °C
- Pt1000 (RTD, 3- or 2-wire)	-200 ÷ 520 °C	- thermocouple E (TC, NiCr-CuNi)	-25 ÷ 820 °C
- Ni100 (RTD, 3- or 2-wire)	-50 ÷ 170 °C	- thermocouple N (TC, NiCrSi-NiSi)	-35 ÷ 1300 °C
- thermocouple J (TC, Fe-CuNi)	-40 ÷ 800 °C	- current (mA, Rwe = 50 Ω)	0/4 ÷ 20 mA
- thermocouple K (TC, NiCr-NiAl)	-40 ÷ 1200 °C	- voltage (V, Rwe = 110 kΩ)	0 ÷ 10 V
- thermocouple S (TC, PtRh 10-Pt)	-40 ÷ 1600 °C	- voltage (mV, Rwe > 2 MΩ)	0 ÷ 60 mV
- thermocouple B (TC, PtRh30PtRh6)	300 ÷ 1800 °C	- resistance (R, 3- or 2-wire)	0 ÷ 2500 Ω
<b>Response time for measurements</b> (0÷90%)	0,5 ÷ 5 s (programmable, default ~1,0 s)		
<b>Resistance of leads</b> (RTD, R)	Rd < 25 Ω (for each line), compensation of line resistance		
<b>Resistive input current</b> (RTD, R)	400 µA (Pt100, Ni100), 200 µA (Pt500, Pt1000, 2500 Ω)		
<b>Processing errors</b> (at 25°C ambient temperature):			
- basic	- for RTD, mA, V, mV, R	0,1 % of the measurement range ±1 digi	
	- for thermocouple	0,2 % of the measurement range ±1 digi	
- additional for thermocouples	< 2 °C (thermocouple cold junction temperature compensation)		
- additional from ambient temp. changes	< 0,004 % of the input range /°C		
<b>Indication range</b> (programmable)	total-1999÷9999 (maximum range of indications for analog inputs)		
<b>Display resolution / dot position</b>	programmable, 8 ÷ 9 9999, for thermometric inputs 0,1 °C or 1 °C		
<b>Outputs P/SSR</b> (3 separate)	- relay P1÷P3	5A/250Vac (for res.), 2 x SPDT, 1 x SPST-NO, standard for outputs 1 1 2	
	- SSR1÷SSR3 (option)	transistor type NPN OC, 11V, current < 23mA, standard for outputs 3	
<b>Analogue output</b> (mA or V, without separation from input)	- current (standard)	0/4 ÷ 20 mA, load Ro < 1 kΩ, max resolution 1,4 µA, 14 bit, active	
	- voltage (option)	0/2 ÷ 10 V, load Io < 3,7mA (Ro > 2,7 kΩ), max resolution 0,7mV, 14 bit	
	- errors (at 25°C)	basic < 0,1 % output range, additional < 0,004 % /°C	
<b>Digital input BIN</b> (2-state)	contact or voltage < 24V, active level: short circuit or < 0,8V		
<b>Power</b> (Usup, universal, comply with the standards 24Vac/dc and 230Vac)	18 ÷ 265 Vac, <3VA (alternating voltage, 50/60Hz) 22 ÷ 350 Vdc, <4W (napiecie stałe)		
<b>Power supply for object transducers</b>	24Vdc/50mA		
<b>Communication interfaces</b> (independent, they can be used simultaneously)	- USB (micro type B, standard)	drivers for the Windows 7/8/10 (virtual serial port COM, communication with computer, MODBUS-RTU protocol, Slave)	
	- RS485 (option)	MODBUS-RTU protocol (Slave), bitrate 2,4÷115,2 kbit/s, programmable sign format (8N1, 8E1, 8o1, 8N2), galvanic separation	
	- Ethernet (option)	RJ45 connector, 10base-T, protocols TCP/IP: MODBUS-TCP (Server), MQTT (client, v.3.1.1), DHCP (client, ICMP (ping)), galvanic separation	
<b>Display</b> (LED with brightness adjustment, signaling status of outputs and measuring units)	top row: white color, 7-segment, height digit 9 mm bottom row: red color, 7-segment, height digit 7 mm		
<b>Rated operating conditions</b>	0 ÷ 50°C, <90 %RH (no condensation) air and neutral gases, no dust		
<b>Protection rating</b>	enclosure IP40, connection side IP20		
<b>Electromagnetic compatibility</b>	immunity: according to the PN-EN 61000-6-2, emission: PN-EN 61000-6-4		
<b>Safety requirements according to PN-EN 61010-1</b>	overvoltage category: II pollution degree: 2 voltage to the ground (earth): 300 V for power supply and output relay circuits 50 V for other inputs/outputs circuits and communication interfaces insulation resistance > 20 MΩ height above sea level < 2000 m		

## Ordering procedure

AR663.B /	<input type="checkbox"/>	<input type="checkbox"/>	<input type="checkbox"/>	<input type="checkbox"/>	<input type="checkbox"/>	<input type="checkbox"/>	<input type="checkbox"/>	<b>Interfece Ethernet * Code</b>	<b>Code</b>
								Ethernet (10base-T)	RJ45

Output 1, 2, 3	Code	Analog output	Code	Interfece RS * Code	Code
relay	P	0/4 ÷ 20 mA	WA	interfece RS485	RS485
SSR ***	S	0/2 ÷ 10 V **	WU		

\* option for an extra fee  
 \*\* output 0/2 ÷ 10 V it is mounted **instead** of the output 0/4 ÷ 20 mA (standard)  
 \*\*\* order with only one SSR output is only available for output 3 (fully functional)

## Order example (standard execution):

### AR663.B / P / P / S / WA

AR663.B, 1 and 2 relay outputs, output 3 for control SSR (NPN-OC), analog output 0/4 ÷ 20 mA (active), without RS485 and Ethernet interfaces

## INSTALLATION DATA

<b>Enclosure and material</b>	on rail, Modulbox 4MH53, PC/ABS self-extinguishing
<b>Dimensions and weight</b>	70 x 90 x 62 mm (without connectors), ~190 g
<b>Fixing methods</b>	on rail TS35 (DIN EN 60715)
<b>Conductor cross-sections</b> (separable connectors)	2.5mm <sup>2</sup> (supply and outputs P/SSR), 1.5mm <sup>2</sup> (others)

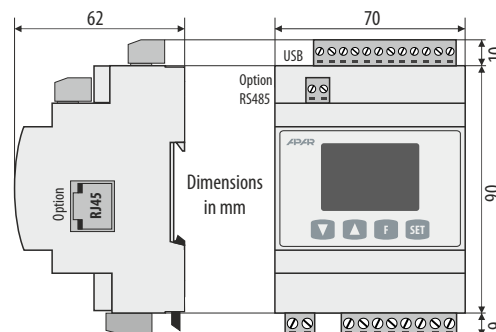

## TERMINAL STRIPS, ELECTRICAL CONNECTIONS

### 1. Description of connectors

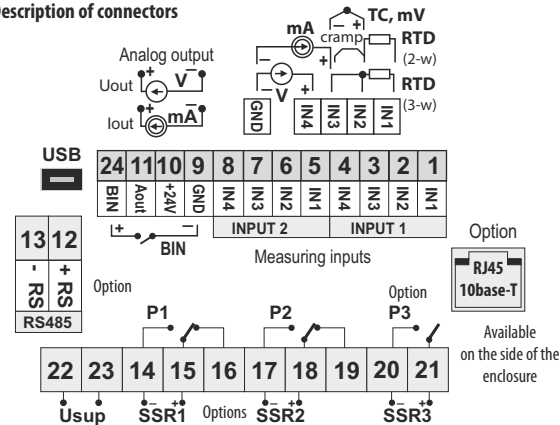

### 2. Connection of a 2- and 3-wire transducer

(Io - current, Uo - voltage output)

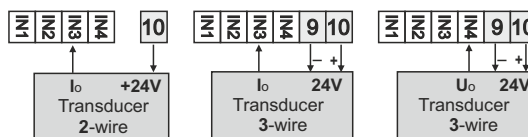

### 3. Connection of a SSR type relay to regulator's control output

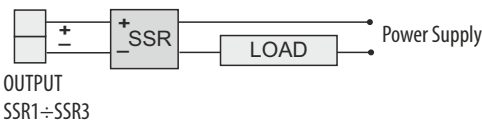

### 4. Galvanic separation of circuits

